

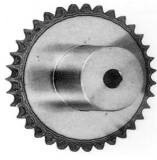

鍊齒輪 SPK RS160



U圓孔(aperture)

T圓孔(aperture)+攻牙(TAP)

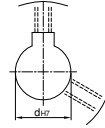
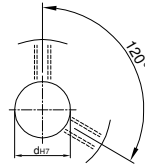
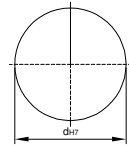
TG NEWS JIS KEY WAY+TAP
TG 新JIS鍵槽+攻牙

| TYPE | 材質 | 表面處理 |
|------|--------|---------|
| SPSD | S45C | HRC+染黑 |
| SPSZ | S45C | HRC+鍍鋅 |
| SPSN | S45C | HRC+鍍鎳 |
| SPSC | S45C | HRC+鍍鎳 |
| SPSH | S45C | HRC+無電鍍 |
| SPSS | SUS303 | 電解 |

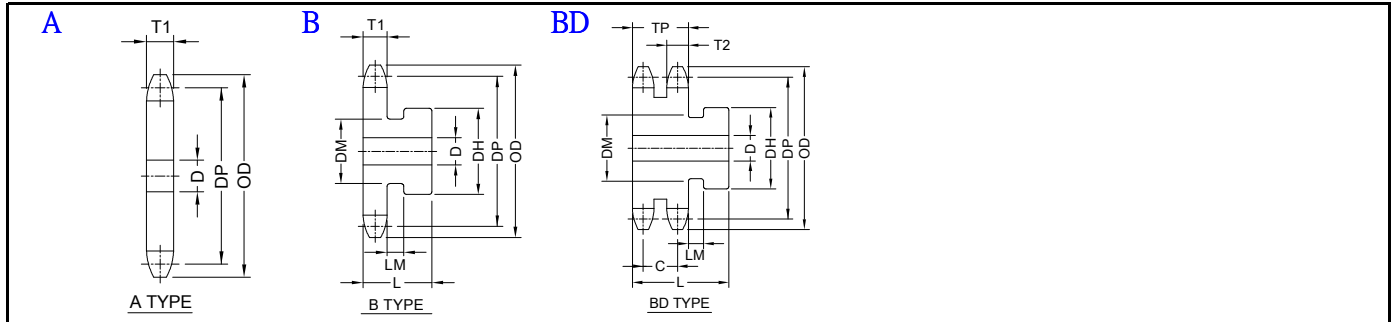

2" PITCH (50.8mm) ▲表示:有截溝 T1=29.4 T2=28.4 TP=86.9 C=58.5

| TYPE | Catalog No. | | | A型 | | B型 | | | | | B D型 | | 節圓直徑 DP | 外徑 OD | | |
|--|-------------|-------|------|------|---------|-------|-----|-------|-------|------|---------|--------|---------|--------|-------|--------|
| | 齒數 T | 齒距 P | 形狀 S | 最小 D | 概略重量 kg | 軸徑 D | | 仔大 DH | 溝槽 DM | 長 L | 概略重量 kg | 最小軸徑 D | | | 仔大 DH | |
| | | | | | | 最小 | 最大 | | | | | | | | | |
| SPSD SPSZ SPSN SPSC SPSH SPSS | 10 | RS160 | A | 1" | 4.61 | 30 | 70 | 127 | 112 | 85 | 6.58 | 30 | 105 | 164.39 | 187 | |
| | 11 | | | 1" | 5.60 | 30 | 80 | 143 | 128 | 85 | 8.12 | 30 | 121 | 180.31 | 204 | |
| | 12 | | | 1" | 6.68 | 30 | 89 | 144 | 85 | 9.70 | 30 | 138 | 196.28 | 220 | | |
| | 13 | | | 1" | 7.86 | 30 | 95 | 150 | 85 | 12.3 | 30 | 155 | 212.27 | 237 | | |
| | 14 | | | 1" | 9.13 | 30 | 95 | 150 | 85 | 13.5 | 30 | 171 | 228.30 | 253 | | |
| | 15 | | | 1" | 10.5 | 38 | 95 | 150 | 85 | 14.9 | 30 | 187 | 224.33 | 269 | | |
| | 16 | | | 1" | 12.0 | 38 | 103 | 150 | 85 | 17.1 | 30 | 204 | 260.39 | 286 | | |
| | 17 | | | 1" | 13.5 | 38 | 103 | 150 | 85 | 18.6 | 30 | 220 | 276.46 | 302 | | |
| | 18 | | | 1" | 15.2 | 38 | 103 | 150 | 85 | 20.3 | 30 | 237 | 292.55 | 319 | | |
| | 19 | | | 1" | 16.9 | 38 | 103 | 150 | 85 | 22.0 | 30 | 253 | 308.64 | 335 | | |
| | 20 | | | 1" | 18.7 | 38 | 103 | 150 | 85 | 23.9 | 30 | 269 | 324.74 | 351 | | |
| | 21 | | | 1" | 20.7 | 38 | 103 | 147 | 75 | 25.8 | 30 | 285 | 340.84 | 368 | | |
| | 22 | | | 1" | 22.7 | 38 | 118 | 167 | 75 | 30.9 | 30 | 302 | 356.96 | 384 | | |
| | 23 | | | 1" | 24.9 | | | | | | 30 | 318 | 373.07 | 400 | | |
| | 24 | | | 1" | 27.0 | B | 1" | 27.0 | 38 | 118 | 167 | 75 | 35.2 | 30 | 334 | 389.19 |
| | 25 | | 1" | 29.3 | 38 | | 118 | 167 | 75 | 37.5 | 30 | 351 | 405.32 | 433 | | |
| | 26 | | 1" | 31.7 | 38 | | 118 | 167 | 75 | 40.0 | | 367 | 421.45 | 449 | | |
| | 27 | | 1" | 34.4 | | | | | | | | 383 | 437.58 | 465 | | |
| | 28 | | 1" | 37.0 | | | | | | | | 399 | 453.72 | 481 | | |
| | 30 | | 1" | 42.3 | 38 | | 118 | 167 | 75 | 53.7 | | 432 | 485.99 | 514 | | |
| | 32 | | 1" | 48.1 | | | | | | | | 464 | 518.28 | 546 | | |
| | 35 | | 1" | 57.6 | 38 | | 118 | 167 | 80 | 69.0 | | 513 | 566.71 | 595 | | |
| | 36 | | 1" | | | | | | | | | | 582.87 | 611 | | |
| | 38 | | 1" | | | | | | | | | | 561 | 615.17 | 644 | |
| | 40 | | 1" | 75.2 | 40 | | 118 | | • 167 | 80 | 88.5 | | 594 | 647.47 | 676 | |
| | 42 | | 1" | | | | | | | | | | 626 | 679.78 | 708 | |
| | 45 | | 1" | 95.2 | 40 | | 132 | | • 187 | 90 | 115 | | 675 | 728.25 | 757 | |
| | 48 | | 1" | 108 | 40 | | 132 | | • 187 | 90 | 128 | | 723 | 776.72 | 806 | |
| | 50 | | 1" | 118 | 40 | | 132 | | • 187 | 90 | 138 | | 756 | 809.04 | 838 | |
| | 54 | | 1" | | 40 | 132 | | • 187 | 90 | 158 | | 821 | 873.68 | 903 | | |
| 60 | 1" | 169 | 40 | 132 | | • 187 | 90 | 189 | | 918 | 970.65 | 1000 | | | | |

Order TYPE — Catalog No. — 軸孔內徑&加工.
 訂貨代號 SPSS — 20RS160B — TG10

註1: 如需規格表以外特殊加工, 請來電告知。

註2: 軸孔配合之鍵槽止付螺絲, 請對照 [孔徑鍵槽止付螺絲對照表](#)

註3: 軸徑D 50以上所配合之鍵槽與止付螺絲請於訂貨代號後附註您所需之尺寸。



孔徑 鍵槽 止付螺絲設計對照表

孔徑&鍵槽尺寸表

| dH7 | 鍵槽寬度bjs9 | | 鍵槽深度 | t公差 |
|-----|----------|---------|------|------------|
| 8 | 3 | ±0.0125 | 1.4 | + 0.1 0 |
| 9 | | | | |
| 10 | | | | |
| 11 | 4 | ±0.015 | 1.8 | |
| 12 | | | | |
| 13 | | | | |
| 14 | 5 | ±0.015 | 2.3 | |
| 15 | | | | |
| 16 | | | | |
| 17 | | | | |
| 18 | 6 | ±0.015 | 2.8 | |
| 19 | | | | |
| 20 | | | | |
| 21 | | | | |
| 22 | 8 | ±0.018 | 3.3 | + 0.2 0 |
| 23 | | | | |
| 24 | | | | |
| 25 | | | | |
| 26 | | | | |
| 28 | | | | |
| 29 | | | | |
| 30 | | | | |
| 31 | | | | |
| 32 | | | | |
| 33 | 10 | ±0.0215 | 3.8 | |
| 34 | | | | |
| 35 | | | | |
| 38 | | | | |
| 40 | 12 | ±0.0215 | 3.8 | |
| 42 | | | | |
| 43 | | | | |
| 44 | | | | |
| 45 | 14 | ±0.0215 | 3.8 | |
| 46 | | | | |
| 47 | | | | |
| 48 | | | | |
| 50 | | | | |
| 50 | | | | |

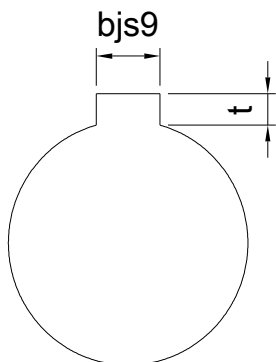

孔徑&止付螺絲對照表

| dH7 | 螺絲規格 |
|------|------|
| 4 | M3 |
| 5 | |
| 6 | |
| 6.35 | |
| 7 | |
| 8 | M4 |
| 9 | |
| 10 | |
| 11 | |
| 12 | M5 |
| 13 | |
| 14 | |
| 15 | |
| 16 | |
| 17 | M6 |
| 18 | |
| 19 | |
| 20 | |
| 21 | |
| 22 | |
| 23 | |
| 24 | |
| 25 | |
| 26 | |
| 28 | M8 |
| 29 | |
| 30 | |
| 31 | |
| 32 | |
| 33 | |
| 34 | |
| 35 | |
| 37 | M10 |
| 38 | |
| 40 | |
| 42 | |
| 43 | |
| 44 | |
| 45 | |
| 46 | |
| 47 | |
| 48 | |
| 50 | |
| 52 | |
| 55 | |
| 57 | |
| 60 | |